

FHI



DRUM CHIPPERS

Drum chippers from Veneer Services[®] will withstand years of heavy use and deliver a consistent, reliable product throughout their lives. We offer two models: Variable-Height Infeed (VHI) for voluminous materials and Fixed-Height Infeed (FHI) for denser materials.

**MORE
UPTIME**

**MORE
FEATURES**

**MORE
VERSATILITY**



www.VeneerServices.com



+1 317-346-0711



Info@VeneerServices.com



DRUM CHIPPERS

Our drum chippers are uniquely designed to reduce maintenance and speed up knife changes. Model VHI features an articulating infeed role while model FHI has a fixed infeed measurement. Both can be used for chipping whole logs, pulp wood, veneer, cores, slabs, scraps, and many other materials.



01

MORE UPTIME

- Unique control system monitors the load on the drum and changes the feed rate accordingly
- If a crash occurs, the knives are pushed back into the drum, allowing obstructions to clear
- Drum is attached to the driveshaft by an expanding ring—a stronger method than keyways
- Can be equipped with a break-away anvil base to pass large pieces without damaging the machine

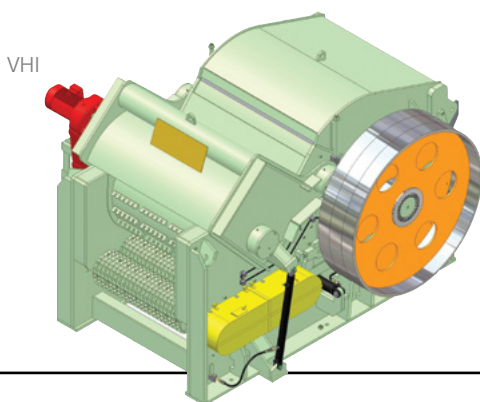

02

MORE FEATURES

- Can easily incorporate metal detectors without fiberglass sections
- Screens ensure an even, consistent chip
- Secondary anvils rechip oversized materials
- Segmented lower rollers allow for easier maintenance and replacement
- Cover opens hydraulically for quick knife changes
- Optional hydraulic disc brake for knife changes or emergency stops



03

MORE VERSATILITY

- Two models for varying needs: Variable-Height Infeed (VHI) and Fixed-Height Infeed (FHI)
- Available from 50 to 2,000 hp
- Output of 7 to 200 tons/hour
- Horizontal or top feed
- Rear or bottom discharge